

# General information

## Cavity

Type series: AL

### Dimensions and sectional view

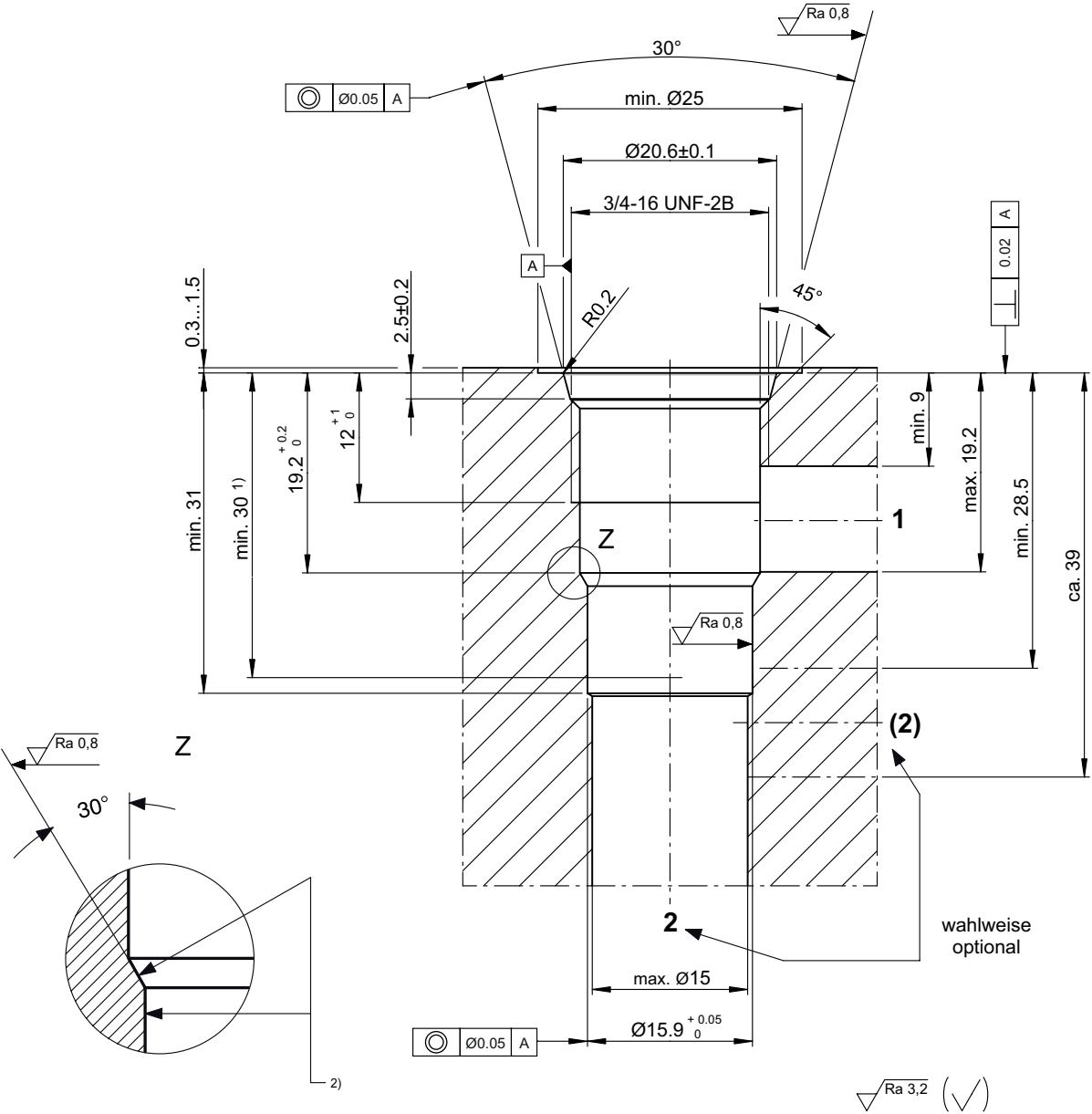

**HINWEIS!  
NOTE!**

- 1) Passungstiefe  
Minimum depth of specified diametral tolerance
- 2) Der Gewindeauslauf darf die Ringfläche und  $\varnothing 15.9$  nicht verletzen.  
The thread runout must not damage the ring surface or the  $\varnothing 15.9$ .

Beispiel für die Masseinheit:  
Example for the dimensional units:  
0.79 = 0.79 mm millimeter

## Installation information



### **ATTENTION!**

You must maintain the specified positional and diametral tolerances. To ensure trouble-free operation of the screw-in cartridges, we strongly recommend that pilot drilling, boring, reaming and cavity thread-cutting are always performed in one setup.



### **NOTE!**

We offer form tool sets for sale or hire. For further information, see data sheet 400-P-040011.



### **NOTE!**

Cavity type to factory standard.